

Victaulic® AGS Flexible Coupling

Style W77/W77N



W77

14 – 24"/DN350 – DN600 sizes
Patented



W77

26 – 60"/DN650 – DN1500 sizes
Patented



W77N

62 – 72"/DN1550 – DN1800 sizes
Patented



1.0 PRODUCT DESCRIPTION

Available Sizes

- 14 – 50"/DN350 – DN1250, Style W77
- 54 – 72"/DN1350 – DN1800, Style W77N
- For sizes larger than 72"/DN1800, see [publication 16.12](#)

Pipe Requirements

- Carbon Steel: see [publication 25.09](#)
- Stainless Steel: see [publication 17.01](#)

Maximum Working Pressure (For Carbon Steel Pipe)

- 14 – 24"/DN350 – DN600: up to 350 psi/2413 kPa
- 26 – 42"/DN650 – DN950: up to 300 psi/2068 kPa
- 44 – 50"/DN1100 – DN1250: up to 232 psi/1599 kPa
- 54 – 64"/DN1350 – DN1550: up to 175 psi/1206 kPa
- 66"/DN1650: up to 125 psi/826 kPa
- 72"/DN1800: up to 75 psi/517 kPa

NOTE

- For Stainless Steel Maximum Working Pressures see [publication 17.09](#).

Application

- Provide limited linear and angular pipe movement at the pipe joint that can be used to compensate for thermal growth of piping systems, vibration attenuation, seismic, differential settlement and other applications requiring flexibility.

Function

- Unique wedge-shaped key profile increases allowable pipe end separation, resulting in easier assembly
- Sizes 26" and larger feature lifting lugs integrated onto the housings to promote ease of handling during installation of the coupling housing.

NOTES

- Style W77 AGS couplings are provided with FlushSeal™ gaskets for a variety of services. Please specify gasket grade when ordering. Please refer to [publication 05.01](#) for gasket service ratings.
- Style W77/W77N AGS flexible couplings can also be used on abrasive/slurry services in combination with an AGS Vic-Ring. See [publication 16.12](#).

ALWAYS REFER TO ANY NOTIFICATIONS AT THE END OF THIS DOCUMENT REGARDING PRODUCT INSTALLATION, MAINTENANCE OR SUPPORT.

2.0 CERTIFICATION/LISTINGS/STANDARDS



NOTES

- Sizes 377mm, 426mm and 480mm are not UL, NSF and FM approved.
- See [publication 02.06](#): Victaulic Potable Water Approvals ANSI/NSF for potable water approvals if applicable.
- Download [publication 10.01](#) for Fire Protection Certifications/Listings Reference Guide

3.0 SPECIFICATIONS – MATERIAL

Housing: Ductile iron conforming to ASTM A536, Grade 65-45-12. Ductile iron conforming to ASTM A395, Grade 65-45-15 available upon special request.

Housing Coating: (specify choice)

Standard: Orange enamel.

Optional: Hot dipped galvanized and others.

Optional: Fusion Bonded Epoxy conforming to AWWA C213

NOTE

- For additional coating options contact Victaulic.

Coupling Gasket: (specify choice¹)

Victaulic Grade “E” FlushSeal™ EPDM

EPDM (Green stripe color code). Temperature range –30°F to +230°F/–34°C to +110°C. May be specified for hot water service within the specified temperature range plus a variety of dilute acids, oil-free air and many chemical services. UL Classified in accordance with ANSI/NSF 61 for cold +73°F/+23°C and hot +180°F/+82°C potable water service and ANSI/NSF 372. **NOT COMPATIBLE FOR USE WITH PETROLEUM SERVICES OR STEAM SERVICES.**

Victaulic Grade “T” FlushSeal™ Nitrile

Nitrile (Orange color code). Temperature range –20°F to +180°F/–29°C to +82°C. May be specified for oil related services, including air with oil vapor, this gasket may be specified for temperatures rated up to +180°F/+82°C. For water related services, this gasket may be specified for temperatures rated up to +150°F/+66°C. For oil free, dry air services, this gasket may be specified for temperatures rated up to +140°F/+60°C. **NOT COMPATIBLE FOR USE WITH HOT WATER SERVICES OR STEAM SERVICES.**

Victaulic Grade “L” FlushSeal™ Silicone

Silicone (Red color code). Temperature range –30°F to +350°F/–34° C to +177° C. May be specified for dry heat, air without hydrocarbons to +350°F/+177°C and certain chemical services.

Others

For alternate gasket selection, reference [publication 05.01](#): Victaulic Seal Selection Guide - Elastomeric Seal Construction.

¹ Services listed are General Service Guidelines only. It should be noted that there are services for which these gaskets are not compatible. Reference should always be made to the latest [Victaulic Seal Selection Guide](#) for specific gasket service guidelines and for a listing of services which are not compatible.

3.0 SPECIFICATIONS – MATERIAL (CONTINUED)

Bolts/Nuts: (specify choice²)

Standard: Carbon steel oval neck track bolts meeting the mechanical property requirements of ASTM A449 (imperial) and ISO 898-1 Class 9.8 (M10-M16) Class 8.8 (M20 and greater). Carbon steel hex nuts meeting the mechanical property requirements of ASTM A563 Grade B (imperial - heavy hex nuts) and ASTM A563M Class 9 (metric - hex nuts). Track bolts and hex nuts are zinc electroplated per ASTM B633 FE/ZN5, finish Type III (imperial) or Type II (metric).

Optional (all sizes): Stainless steel oval neck track bolts or studs meeting the mechanical property requirements of ASTM A193 Grade B8M, Class 2 (316 stainless steel). Stainless steel heavy hex nuts meeting the mechanical property requirements of ASTM A194 Grade 8M (316 stainless steel) with galling reducing coating.

Optional (for 14-24"/DN350-DN600 sizes only): Stainless steel oval neck track bolts meeting the mechanical property requirements of ASTM F593, Group 2 (316 stainless steel), condition CW. Stainless steel heavy nuts meeting the mechanical property requirements of ASTM F594, Group 2 (316 stainless steel), condition CW, with galling reducing coating.

For 26 – 72"/DN650 – DN1800 sizes:

Washers: Plated carbon steel, flat. SAE high strength conforming to ASTM F436 or high strength stainless steel.

² Optional bolts/nuts are available in imperial sizes only

4.0 DIMENSIONS

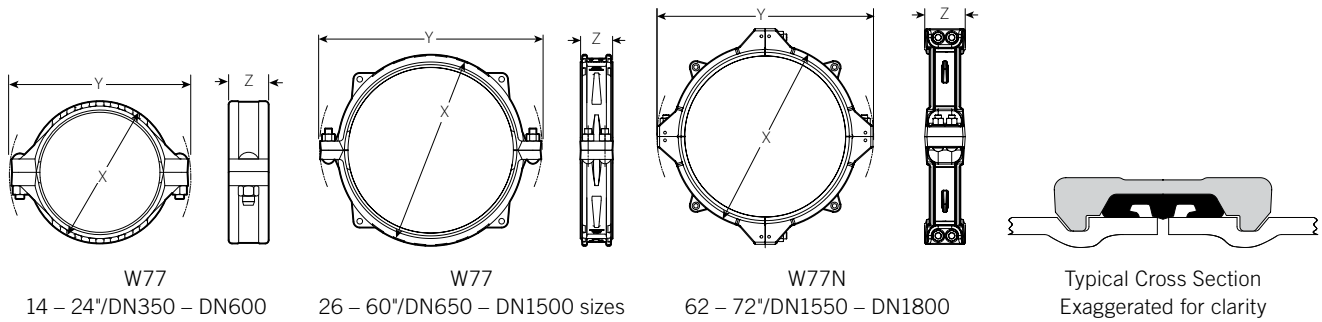

Size		Pipe End Separation	Deflect. From CL		Bolt/Nut		Dimensions			Weight
Nominal inches DN	Actual Outside Diameter inches mm	Allowable inches mm	Per Cplg. Deg.	in/ft mm/m	Qty.	Size inches	X inches mm	Y inches mm	Z inches mm	Approximate (Each) lb kg
14 DN350	14.0 355.6	0.13 – 0.31 3.3 – 7.9	0.73	0.15 13	2	1 x 5 ½	16.25 413	20.25 514	4.75 121	50.0 22.7
	14.8 377.0	0.13 – 0.31 3.3 – 7.9	0.69	0.14 12	2	M24 X 139.7	16.84 428	21.44 545	4.54 115	52.6 23.9
16 DN400	16.0 406.4	0.13 – 0.31 3.3 – 7.9	0.63	0.13 11	2	1 x 5 ½	18.25 464	22.50 572	4.75 121	60.0 27.2
	16.8 426.0	0.13 – 0.31 3.3 – 7.9	0.61	0.13 11	2	M24 X 139.7	18.95 481	23.47 596	4.55 116	63.1 28.6
18 DN450	18.0 457.0	0.13 – 0.31 3.3 – 7.9	0.57	0.12 10	2	1 x 5 ½	20.50 521	24.50 622	4.75 121	65.0 29.5
	18.9 480.0	0.13 – 0.31 3.3 – 7.9	0.54	0.11 9	2	M24 X 139.7	25.72 653	21.26 540	4.55 116	75.7 34.3
20 DN500	20.0 508.0	0.13 – 0.31 3.3 – 7.9	0.50	0.10 9	2	1 ½ x 5 ½	22.75 578	27.25 692	4.75 121	85.0 38.6
	22 DN550	22.0 559.0	0.13 – 0.31 3.3 – 7.9	0.50	0.10 9	1.125 x 6	24.75 629	29.50 749	4.75 121	99.0 44.9
24 DN600	24.0 610.0	0.13 – 0.31 3.3 – 7.9	0.42	0.09 8	2	1 ½ x 5 ½	27.00 686	31.50 800	4.75 121	110.0 49.9
	26 DN650	26.0 660.4	0.15 – 0.53 3.8 – 13.5	0.83	0.18 15	1 ½ x 6	29.25 743	35.25 895	5.75 146	205.0 93.0
28 DN700	28.0 711.2	0.15 – 0.53 3.8 – 13.5	0.78	0.16 14	4	1 ½ x 6	31.25 794	37.25 946	5.75 146	220.0 99.8
	30 DN750	30.0 762.0	0.15 – 0.53 3.8 – 13.5	0.73	0.16 13	1 ¼ x 7	33.25 845	39.75 1010	5.75 146	230.0 104.3
32 DN800	32.0 812.8	0.15 – 0.53 3.8 – 13.5	0.68	0.14 11	4	1 ¼ x 7	35.25 895	41.75 1060	5.75 146	245.0 111.1
	34 DN850	34.0 865.0	0.15 – 0.53 3.8 – 13.5	0.69	0.13 11	1 ¼ x 7	37.25 946	43.75 1111	5.75 146	255.0 115.7
36 DN900	36.0 914.4	0.15 – 0.53 3.8 – 13.5	0.60	0.13 11	4	1 ¼ x 7	39.25 997	45.75 1162	5.75 146	270.0 122.5

NOTES

- The outside diameter, ovality, and surface finish including flat spots and imperfections shall not vary more than the limits of API 5L end tolerance.
- See [publication 25.09](#): Advanced Groove System (AGS) Roll Groove Specifications for proper groove specifications.
- Additional wall thicknesses available. For performance on additional pipe wall thicknesses contact Victaulic.
- For additional pipe sizes, please contact Victaulic.

4.0 DIMENSIONS (CONTINUED)

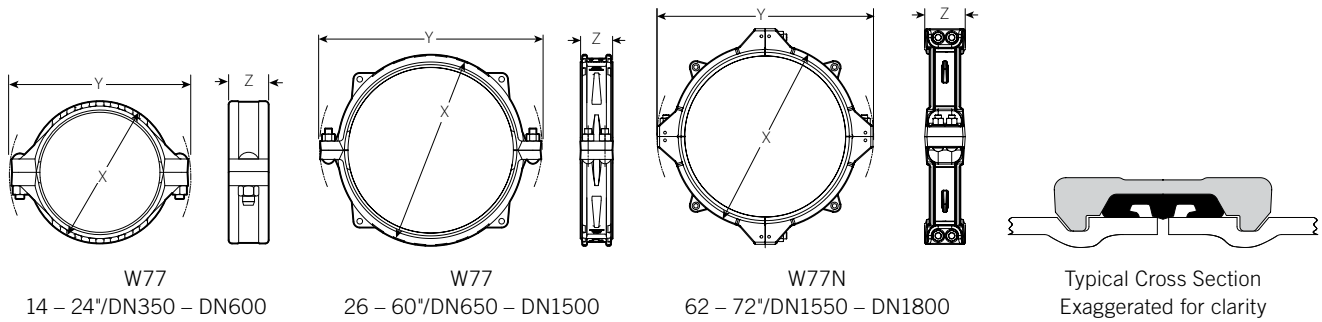

Size		Pipe End Separation	Deflect. From CL		Bolt/Nut		Dimensions			Weight
Nominal inches DN	Actual Outside Diameter inches mm	Allowable inches mm	Per Cplg. Deg.	in/ft mm/m	Qty.	Size inches	X inches mm	Y inches mm	Z inches mm	Approximate (Each) lb kg
38 DN950	38.0 965.0	0.15 - 0.53 3.8 - 13.5	0.57	0.13 11	4	1 1/4 x 7	41.25 1048	47.75 1213	5.75 146	300.0 136.1
40 DN1000	40.0 1016.0	0.21 - 0.59 5.3 - 15.0	0.55	0.12 10	4	1 1/2 x 8	43.25 1009	50.75 1289	6.5 165	340.0 154.2
42 DN1050	42.0 1066.8	0.21 - 0.59 5.3 - 15.0	0.52	0.11 9	4	1 1/2 x 8	45.25 1149	52.50 1334	6.5 165	360 163.3
44 DN1100	44.0 1117.6	0.21 - 0.59 5.3 - 15.0	0.49	0.10 8	4	1 1/2 x 8	47.50 1207	54.50 1384	6.5 165	390 176.9
46 DN1150	46.0 1168.4	0.21 - 0.59 5.3 - 15.0	0.47	0.10 8	4	1 1/2 x 8	49.50 1257	56.50 1435	6.5 165	415 188.2
48 DN1200	48.0 1219.2	0.21 - 0.59 5.3 - 15.0	0.45	0.10 8	4	1 1/2 x 8	51.50 1308	58.50 1486	6.5 165	425 192.8
50 DN1250	50.0 1270.0	0.21 - 0.59 5.3 - 15.0	0.43	0.09 8	4	1 1/2 x 8	53.75 1365	61.00 1549	10 254	535.0 242.7
54 DN1350	54.0 1371.6	0.28 - 0.66 7.1 - 16.8	0.40	0.08 7	4	1 1/2 x 8	58.00 1473	65.25 1657	10 254	650.0 294.8
56 DN1400	56.0 1422.2	0.28 - 0.66 7.1 - 16.8	0.38	0.08 7	4	1 1/2 x 8	60.00 1524	67.75 1721	10 254	700.0 317.5
60 DN1500	60.0 1524.0	0.28 - 0.66 7.1 - 16.8	0.36	0.08 7	4	1 1/2 x 8	64.00 1626	72.25 1835	10 254	720.0 326.6
62 DN1550	62.0 1574.8	0.28 - 0.66 7.1 - 16.8	0.35	0.07 6	8	1 1/2 x 8	67.50 1715	73.75 1873	10 254	960.0 435.4
64 DN1600	64.0 1625.6	0.28 - 0.66 7.1 - 16.8	0.34	0.07 6	8	1 1/2 x 8	69.75 1772	76.00 1930	10 254	1030.0 467.2
66 DN1650	66.0 1676.4	0.28 - 0.66 7.1 - 16.8	0.33	0.06 5	8	1 1/2 x 8	71.75 1822	79.25 2013	11 279	1190.0 539.8
72 DN1800	72.0 1828.8	0.28 - 0.66 7.1 - 16.8	0.30	0.06 5	8	1 1/2 x 8	77.50 1969	85.25 2165	10.5 267	1200 544.3

NOTES

- The outside diameter, ovality, and surface finish including flat spots and imperfections shall not vary more than the limits of API 5L pipe end tolerances.
- See [publication 25.09](#): Advanced Groove System (AGS) Roll Groove Specifications for proper groove specifications.
- Additional wall thicknesses available. For performance on additional pipe wall thicknesses contact Victaulic.
- For additional pipe sizes, please contact Victaulic.

5.0 PERFORMANCE

Style W77 (For Carbon Steel Pipe)

Size		Maximum Working Pressure			Max. End Load ⁴	Activation Moment ⁵
Nominal inches DN	Actual Outside Diameter inches mm	Light Wall ³ psi kPa	Std. Wt. ¾" psi kPa	XS ½" psi kPa		
14 DN350	14.000	350	350	350	55800	31,500
	355.6	2413	2413	2413	248310	42,708
	14.843	350	350	350	60562	37,500
	377.0	2413	2413	2413	269393	50,843
16 DN400	16.000	350	350	350	72885	47,000
	406.4	2413	2413	2413	324209	63,723
	16.772	350	350	350	77326	54,100
	426.0	2413	2413	2413	343963	73,350
18 DN450	18.000	350	350	350	92245	66,800
	457.0	2413	2413	2413	410326	90,569
	18.898	350	350	350	98172	77,400
	480.0	2413	2413	2413	436691	104,940
20 DN500	20.000	350	350	350	113880	91,700
	508.0	2413	2413	2413	506563	124,329
22 DN550	22.000	350	350	350	133046	122,000
	559.0	2413	2413	2413	591818	165,410
24 DN600	24	225	–	–	101790	101,800
	610	1551	–	–	456426	138,022
24 DN600	24	–	350	350	163990	158,400
	610	–	2413	2413	729464	214,762
26 DN650	26.000	300	300	300	159279	172,600
	660.4	2068	2068	2068	708508	234,014
28 DN700	28.000	300	300	300	184726	215,600
	711.2	2068	2068	2068	821702	292,314
30 DN750	30.000	300	300	300	212058	265,100
	762.0	2068	2068	2068	943281	359,427
32 DN800	32.000	300	300	300	241274	321,700
	812.8	2068	2068	2068	1073240	436,167
34 DN850	34.000	300	300	300	272375	385,900
	865.0	2068	2068	2068	1211584	523,210
36 DN900	36.000	300	300	300	305363	458,100
	914.4	2068	2068	2068	1358322	621,100

³ Light Wall for 14"/DN350 = 0.22"/5.6mm; 16 – 24"/DN400 – DN600 = 0.25"/6.4mm, 26 – 50"/DN650 – DN1250 = 0.312"/7.9mm
Light Wall for 377mm = 0.217"/5.5mm; 426mm = 0.256"/6.5mm; 480mm = 0.256"/6.5mm

⁴ End loads are total from all internal and external loads, based on carbon steel pipe, rolled with Victaulic AGS rolls in accordance with [Victaulic AGS roll groove specifications](#). Contact Victaulic for performance on other pipe.

⁵ Victaulic Style W77/W77N require an activation moment resulting in reaction forces and moments in the system. This moment is linearly proportional to the system MAWP and can be determined for system design pressure through this linear relationship. The design activation moment shall be used for piping system and structural design purposes.

NOTES

- WARNING: FOR ONE TIME FIELD TEST ONLY, the Maximum Joint Working Pressure may be increased to 1 ½ times the figures shown.
- Additional wall thicknesses available. For performance on additional pipe wall thicknesses contact Victaulic.
- For additional pipe sizes, please contact Victaulic.
- AGS is a fully self-restrained joint.
- Contact Victaulic for sizes greater than 72"/DN1800.

5.0 PERFORMANCE (CONTINUED)

Style W77 (For Carbon Steel Pipe)

Size		Maximum Working Pressure			Max. End Load ⁴	Activation Moment ⁵
Nominal inches DN	Actual Outside Diameter inches mm	Light Wall ³ psi kPa	Std. Wt. 3/8" psi kPa	XS 1/2" psi kPa		
38 DN950	38.0 965.0	300 2068	300 2068	300 2068	340235 1513440	538,800 730,515
40 DN1000	40.0 1016.0	300 2068	300 2068	300 2068	376991 1676940	628,400 851,996
42 DN1050	42.0 1066.8	300 2068	300 2068	300 2068	415632 1848823	727,400 986,222
44 DN1100	44.0 1117.6	232 1599	232 1599	232 1599	352763 1569168	646,800 876,943
46 DN1150	46.0 1168.4	232 1599	232 1599	232 1599	385561 1715061	739,000 1,001,949
48 DN1200	48.0 1219.2	232 1599	232 1599	232 1599	419820 1867452	840,000 1,138,887
50 DN1250	50.0 1270.0	232 1599	232 1599	232 1599	455530 2026298	950,000 1,288,027
54 DN1350	54.0 1371.6	-	175 1206	175 1206	400790 1782802	902,000 1,222,948
56 DN1400	56.0 1422.2	-	175 1206	175 1206	431030 1917317	1,006,000 1,363,953
60 DN1500	60.0 1524.0	-	175 1206	175 1206	494800 2200980	1,238,000 1,678,503
62 DN1550	62.0 1574.8	-	175 1206	175 1206	528340 2350173	1,365,000 1,850,691
64 DN1600	64.0 1625.6	-	-	175 1206	562980 2504260	1,502,000 2,036,439
66 DN1650	66.0 1676.4	-	-	125 862	427432 1901312	1,177,000 1,595,798
72 DN1800	72.0 1828.8	-	-	75 517	305363 1358322	917,000 1,243,285

³ Light Wall for 14"/DN350 = 0.22"/5.6mm; 16 - 24"/DN400 - DN600 = 0.25"/6.4mm, 26 - 50"/DN650 - DN1250 = 0.312"/7.9mm
Light Wall for 377mm = 0.217"/5.5mm; 426mm = 0.256"/6.5mm; 480mm = 0.256"/6.5mm

⁴ End loads are total from all internal and external loads, based on carbon steel pipe, rolled with Victaulic AGS rolls in accordance with [Victaulic AGS roll groove specifications](#). Contact Victaulic for performance on other pipe.

⁵ Victaulic Style W77/W77N require an activation moment resulting in reaction forces and moments in the system. This moment is linearly proportional to the system MAWP and can be determined for system design pressure through this linear relationship. The design activation moment shall be used for piping system and structural design purposes.

NOTES

- WARNING: FOR ONE TIME FIELD TEST ONLY, the Maximum Joint Working Pressure may be increased to 1 1/2 times the figures shown.
- Additional wall thicknesses available. For performance on additional pipe wall thicknesses contact Victaulic.
- For additional pipe sizes, please contact Victaulic.
- Contact Victaulic for sizes greater than 72"/DN1800.

5.1 PERFORMANCE

Torque Requirements

Coupling Size inches DN	Required Torque ft. lbs. N•m
14, 16, 18 350, 400, 450	250 340
377, 426, 480mm	250 340
20, 22, 24, 26, 28 500, 550, 600, 650, 700	375 500
30, 32, 34, 36, 38 750, 800, 850, 900, 950	500 680
40, 42, 44, 46, 48, 50 1000, 1050, 1100, 1150, 1200, 1250	600 813
54, 56, 58, 60, 62, 64, 66, 72 1350, 1400, 1450, 1500, 1550, 1600, 1650, 1800	600 813

6.0 NOTIFICATIONS

WARNING

- When grooving pipe for use with AGS products, Victaulic roll grooving tools must be equipped with AGS roll sets (RW for steel or RWX for stainless steel).
- RWX grooving rolls are identified by a silver color and the designation "RWX" on the front of the roll sets.
- Victaulic AGS products MUST NOT be installed on pipe that is prepared with original-type grooving roll sets.
- To ensure proper pipe end preparation refer to [publication 25.09](#) for AGS (Advanced Groove System) roll groove pipe specifications.

Failure to follow these instructions will cause grooves that are not within Victaulic AGS specifications, resulting in joint failure, serious personal injury, and property damage.

7.0 REFERENCE MATERIALS

- [02.06: Victaulic® Potable Water Approvals ANSI/NSF](#)
- [05.01: Victaulic® Seal Selection Guide](#)
- [16.12: Victaulic® AGS Vic-Ring Systems](#)
- [17.01 Victaulic Stainless Steel Pipe Grooving](#)
- [20.05: Victaulic® AGS Grooved End Fittings](#)
- [20.12 Victaulic W155 Expansion Joints](#)
- [20.16 Style W257 Dynamic Movement Joint](#)
- [23.19 Series W719 Butterfly Valve](#)
- [24.01: Victaulic® Pipe Preparation Tool Specifications](#)
- [25.09: Victaulic® AGS Roll Groove Specifications](#)
- [26.01: Victaulic® Design Data](#)
- [29.01: Victaulic® Terms and Conditions/Warranty](#)
- [I-ENDCAP: Victaulic® End Caps Installation Instructions](#)

User Responsibility for Product Selection and Suitability

Each user bears final responsibility for making a determination as to the suitability of Victaulic products for a particular end-use application, in accordance with industry standards and project specifications, and the applicable building codes and related regulations as well as Victaulic performance, maintenance, safety, and warning instructions. Nothing in this or any other document, nor any verbal recommendation, advice, or opinion from any Victaulic employee, shall be deemed to alter, vary, supersede, or waive any provision of Victaulic Company's standard conditions of sale, installation guide, or this disclaimer.

Intellectual Property Rights

No statement contained herein concerning a possible or suggested use of any material, product, service, or design is intended, or should be construed, to grant any license under any patent or other intellectual property right of Victaulic or any of its subsidiaries or affiliates covering such use or design, or as a recommendation for the use of such material, product, service, or design in the infringement of any patent or other intellectual property right. The terms "Patented" or "Patent Pending" refer to design or utility patents or patent applications for articles and/or methods of use in the United States and/or other countries.

Note

This product shall be manufactured by Victaulic or to Victaulic specifications. All products to be installed in accordance with current Victaulic installation/assembly instructions. Victaulic reserves the right to change product specifications, designs and standard equipment without notice and without incurring obligations.

Installation

Reference should always be made to the Victaulic installation handbook or installation instructions of the product you are installing. Handbooks are included with each shipment of Victaulic products, providing complete installation and assembly data, and are available in PDF format on our website at www.victaulic.com.

Warranty

Refer to the Warranty section of the current Price List or contact Victaulic for details.

Trademarks

Victaulic and all other Victaulic marks are the trademarks or registered trademarks of Victaulic Company, and/or its affiliated entities, in the U.S. and/or other countries.